

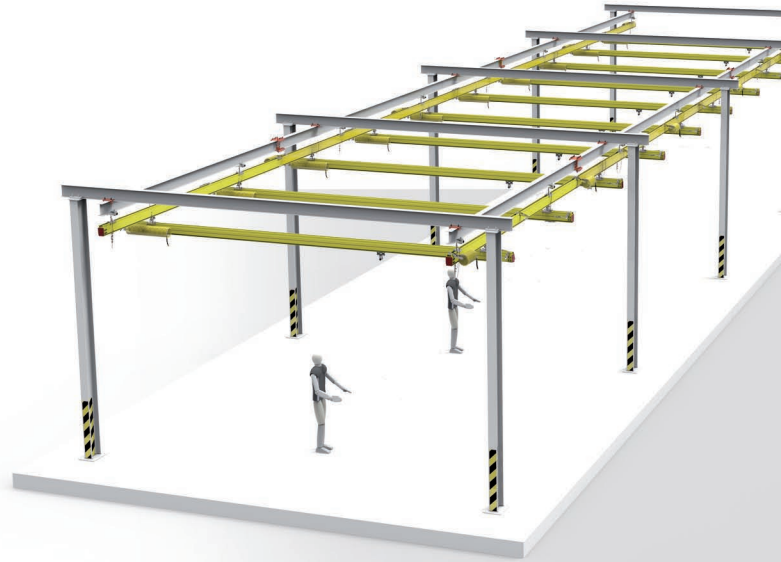

MANIPULATORS

- Torque tubes
- Ergonomics and Safety for the operators
- Engineering studies based on simulations



MODULAR DESIGN REUSABLE STRUCTURES

(Patented)

- Cost effective
- Easy and fast installation
- 100% Reusable (weld-free) and long life



JIB CRANES

- The Jib Cranes work with aluminum or steel rails
- Cranes 220 ° and 360 ° arm rotation
- Ideal for short load transfers

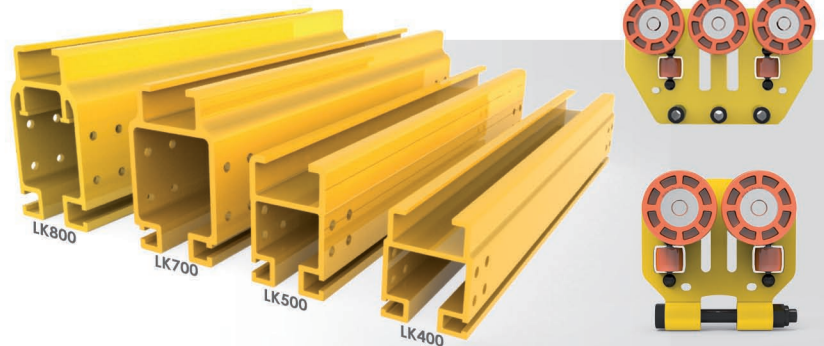

RUNWAYS AND CRANES

- Ideal for assembly lines
- Suspended Runways and Cranes
- Single and Double bridge Rail System

Load Capacity :

- 3500 lbs (1600 Kgs)
- 7000 lbs (3200 Kgs)

Benefits:

- ✓ Cost effective.
- ✓ Easy and fast installation.
- ✓ 100% Reusable (weld-free) and long life.
- ✓ Flexible and adaptable to process needs.

Applications:

- Assembly lines.
- Upholstery and lightening lines.
- Suspension loads.
- Equipment and tool loading.

 Floor Structure Fig. 1 to 11
 Suspended Structure Fig. 12 to 18

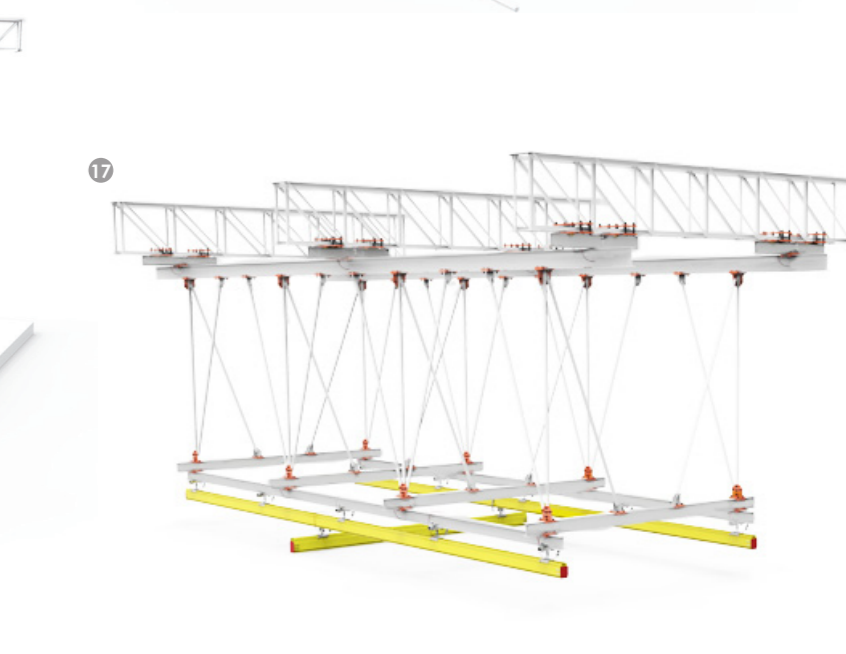
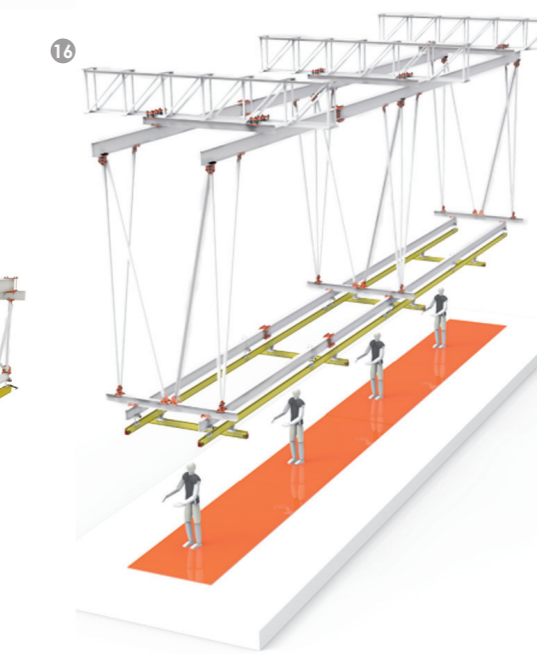
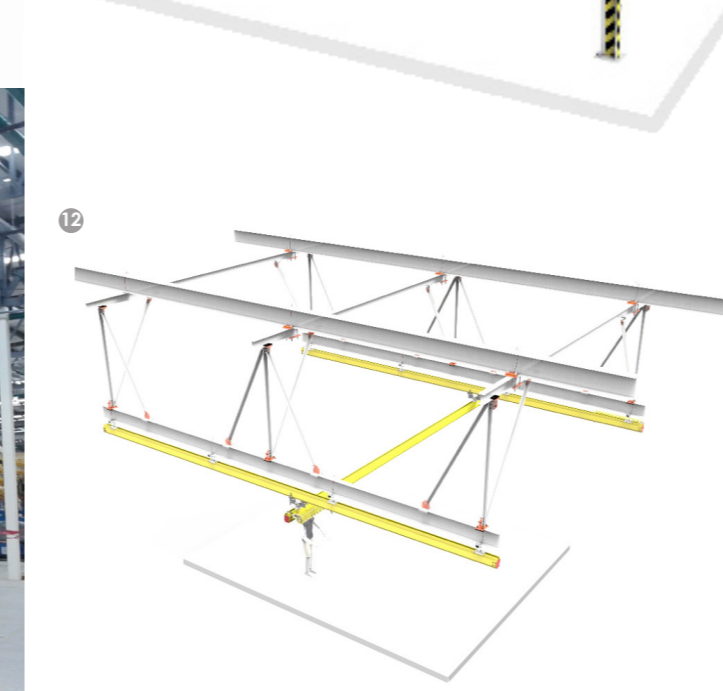
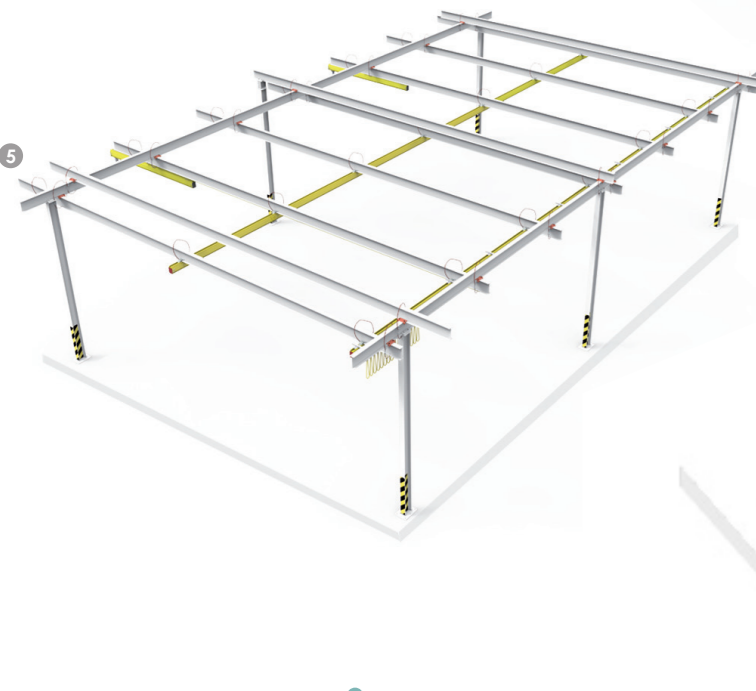
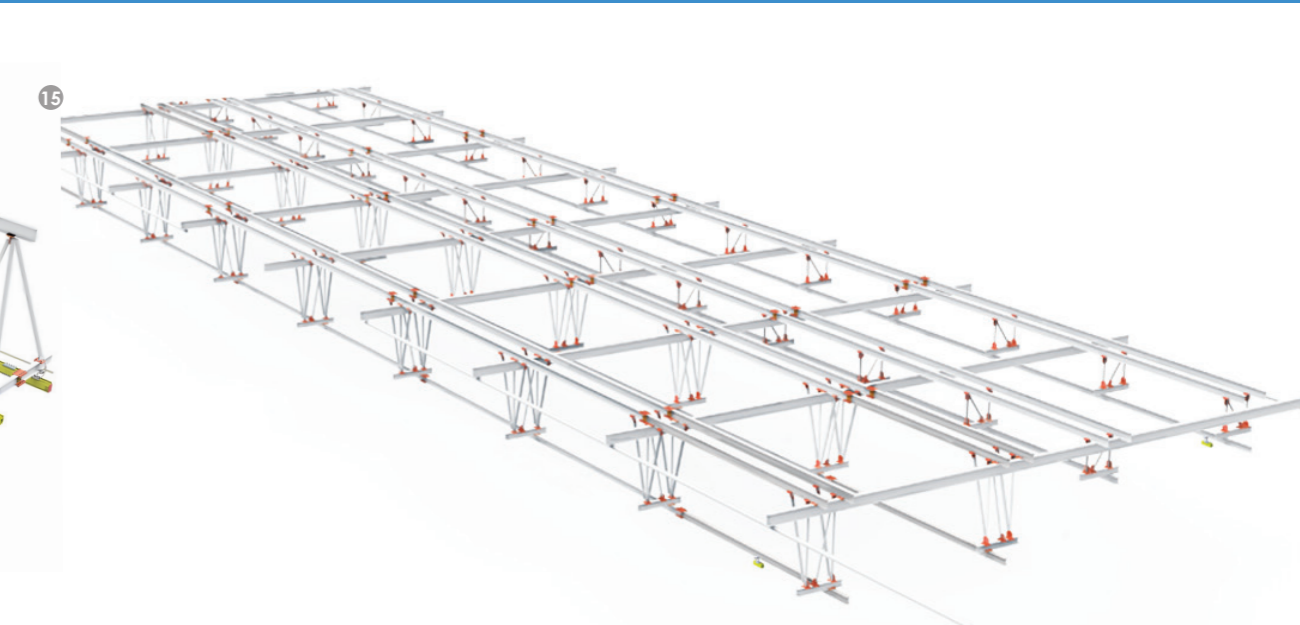
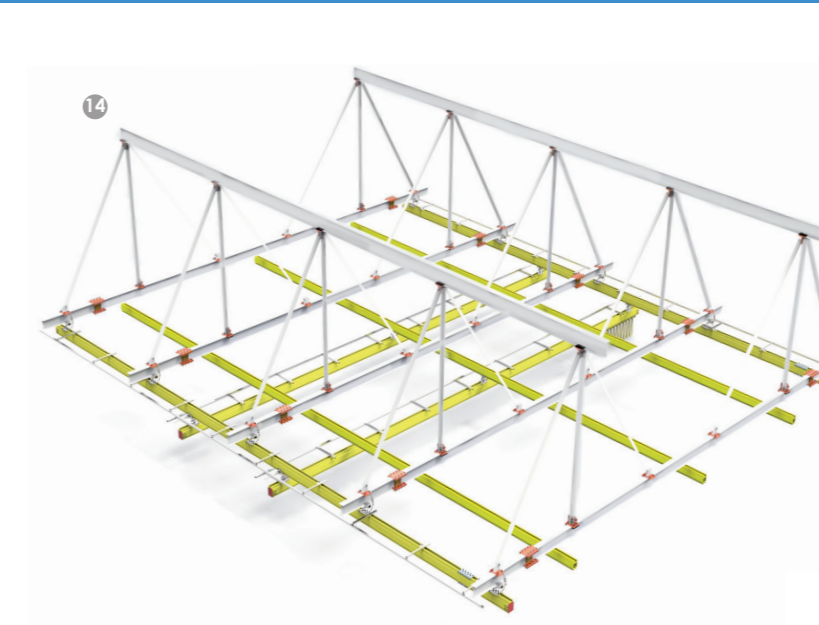
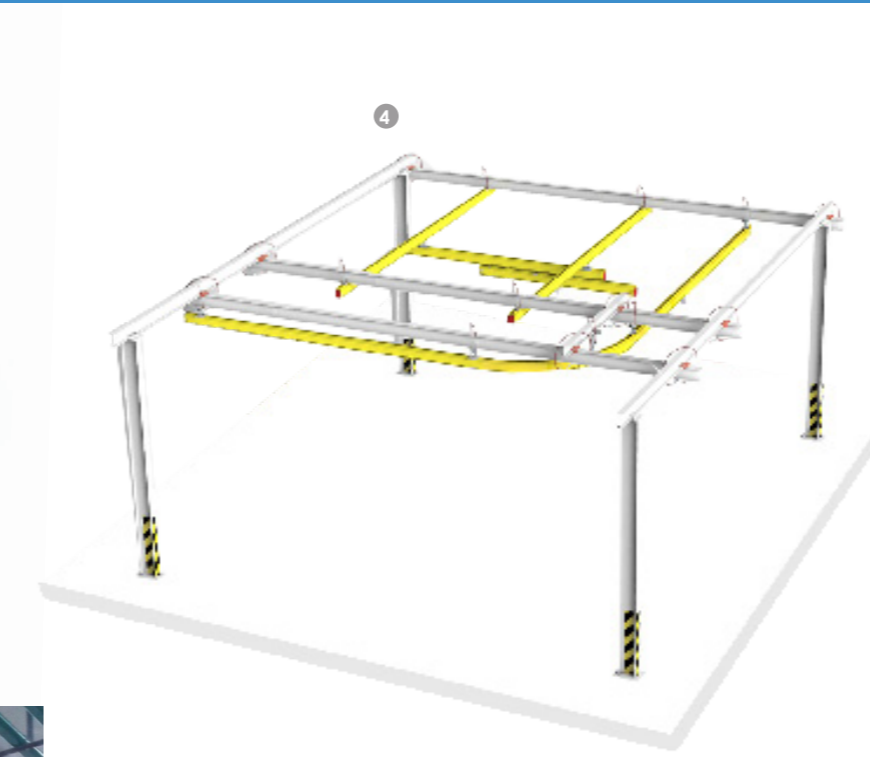

ALKA USA Inc. Mounting Clips

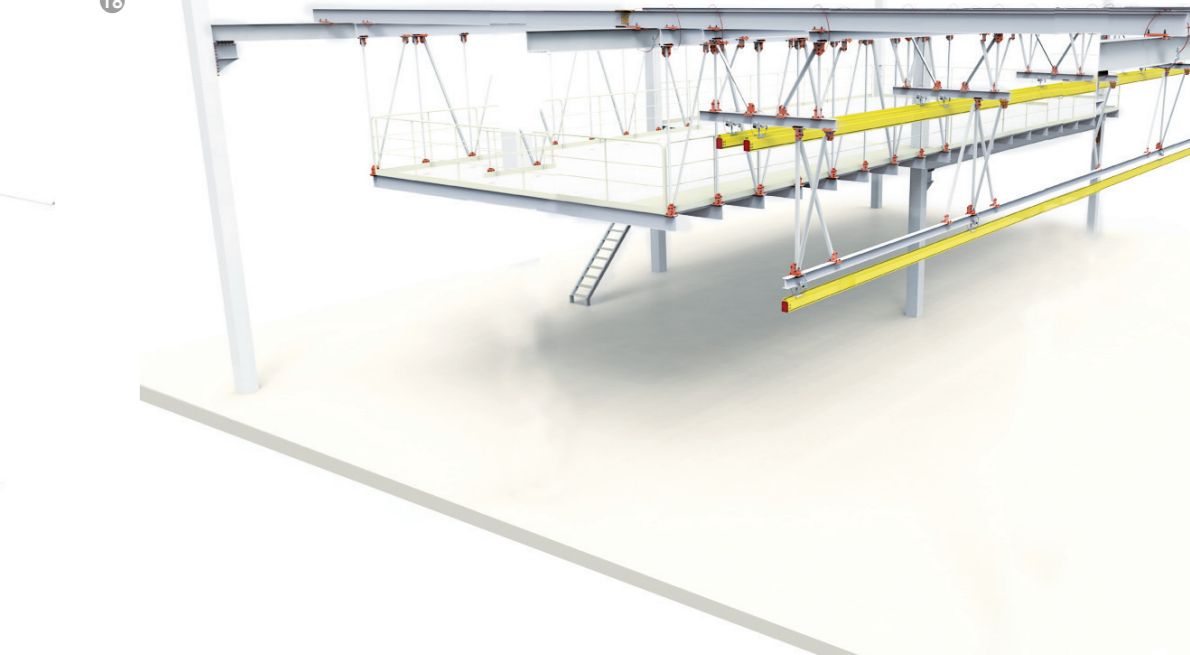
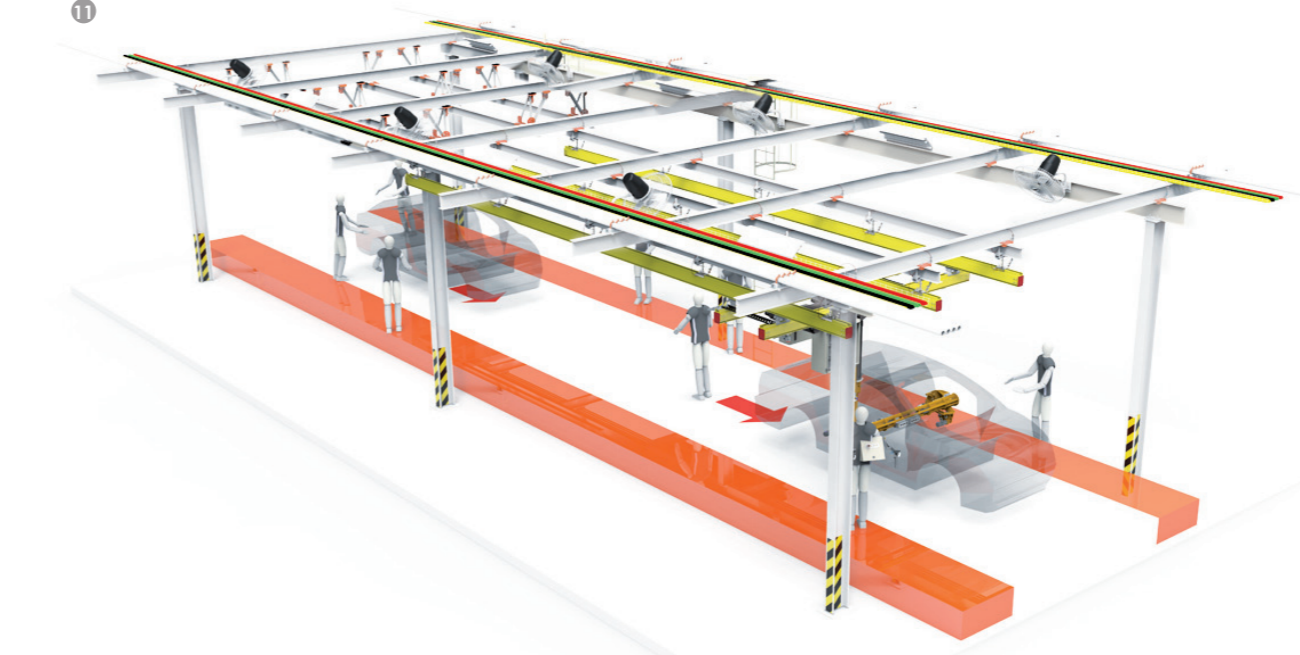
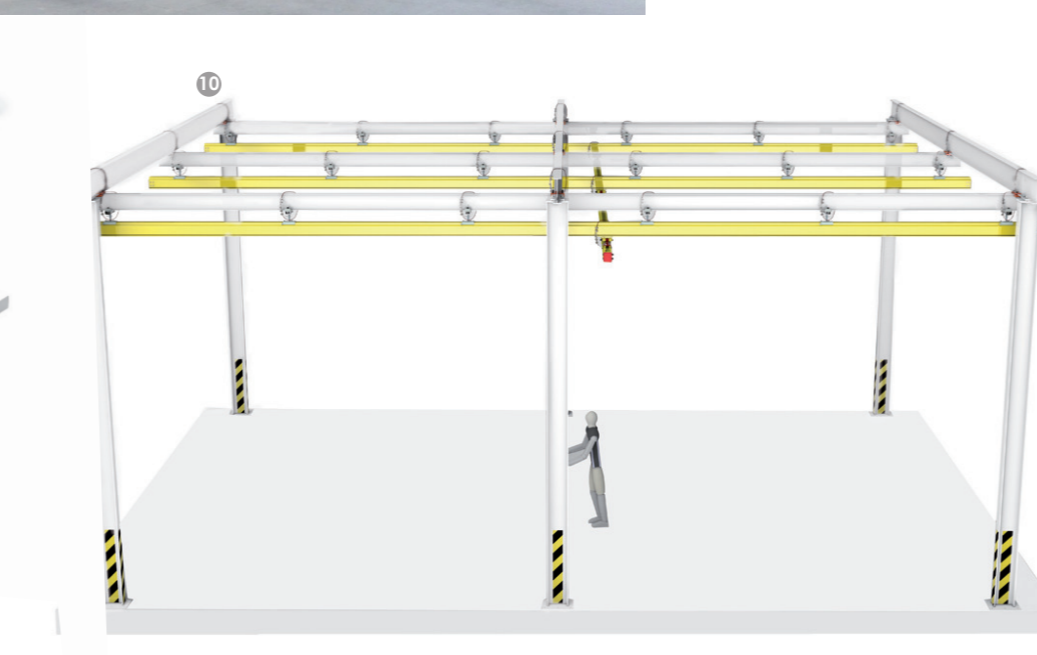
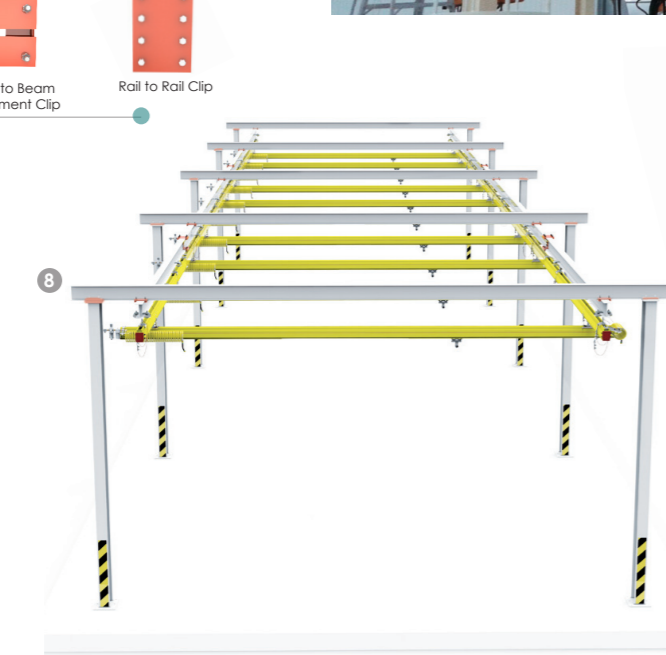
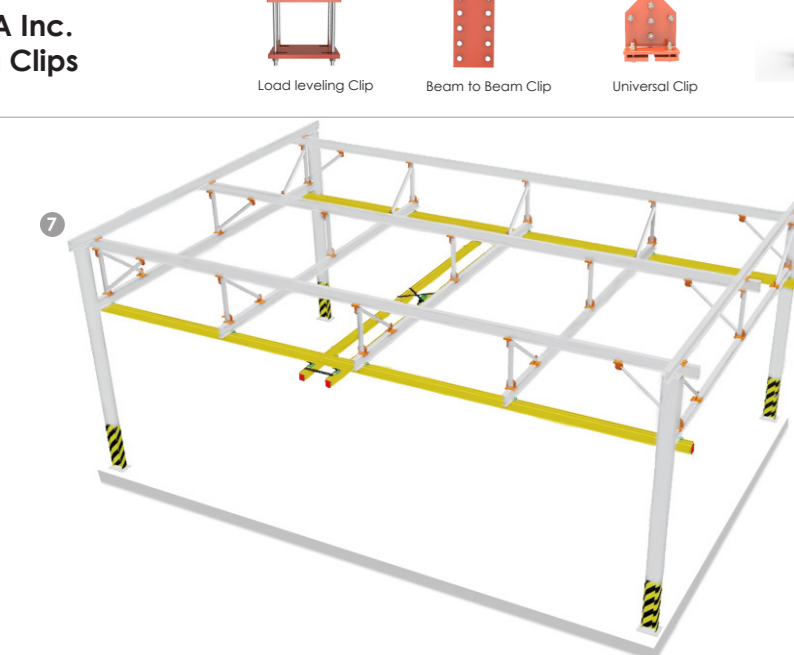

Manipulators

Lift Assist and End Effectors

- We produce engineering precision and manufacturing quality through **Technology**.
- Development of Handling Material, Solutions and Lift Assist according to industry requirements.
- Different capacity **Torque Tubes** with designs ergonomics and safety that reduce operators fatigue.
- End Effectors for different configurations, pneumatic, electric, and servo-assisted according to level precision that required by the application.



Cylinders Transfer



Dual Torque Tool

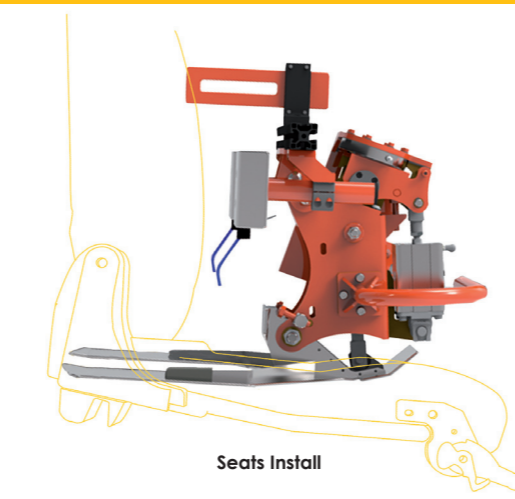

Seats Install



Fuel Tank Lifting Device

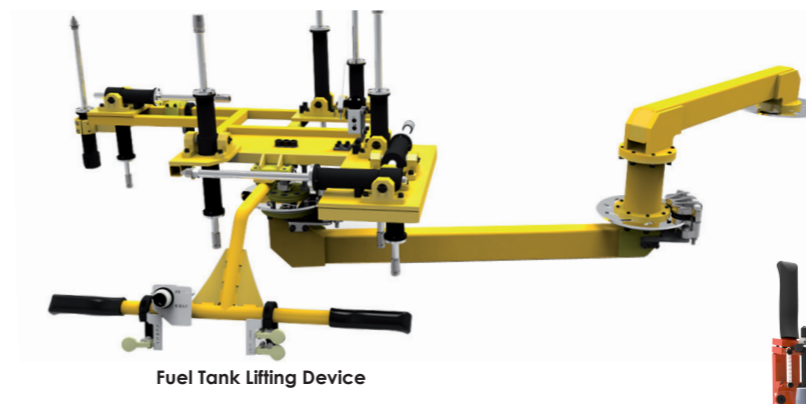

Fuel Tank Lifting Device



Trombone with a nutrunner

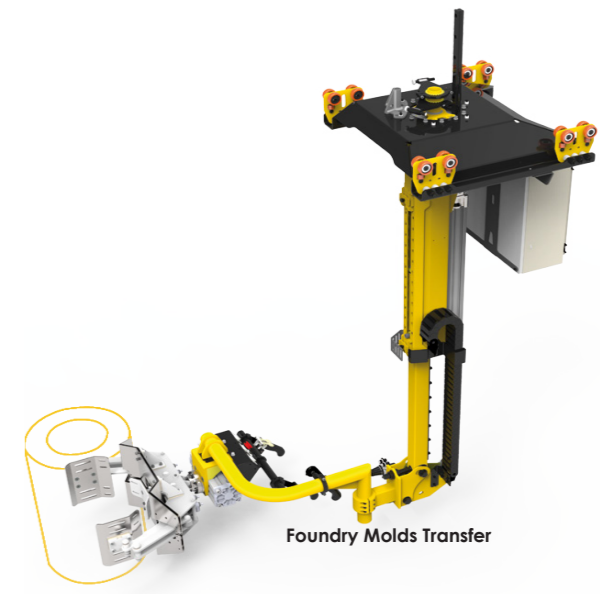

Foundry Molds Transfer

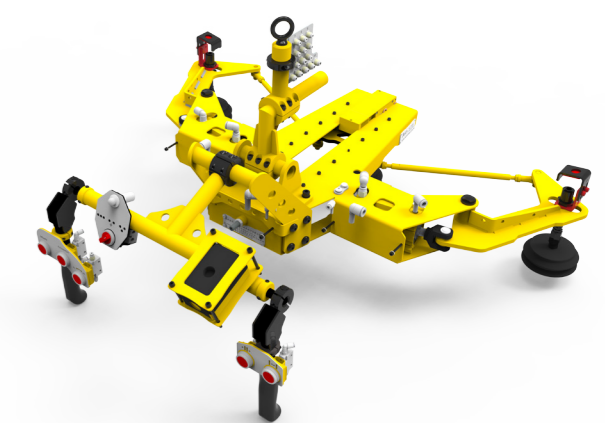

Automatic Adjustment



Trombone with a nutrunner



Trombone with a nutrunner



Torque Tube Low Capacity



Battery Install



Automatic Transfer



Fuel Tank Lifting Device

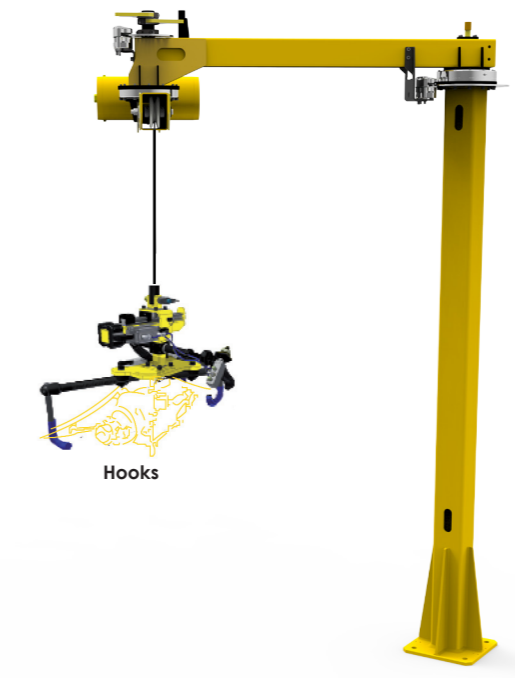

Hooks



Rear Seat Lift

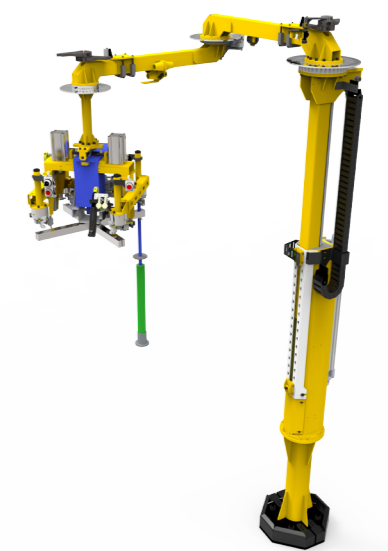

Transfer and Assembly of Foundry Molds

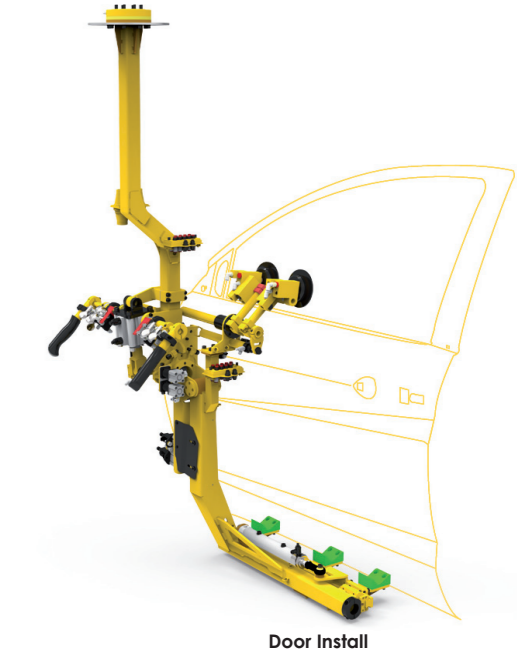

Door Install



Tire Install



Transfer Tires

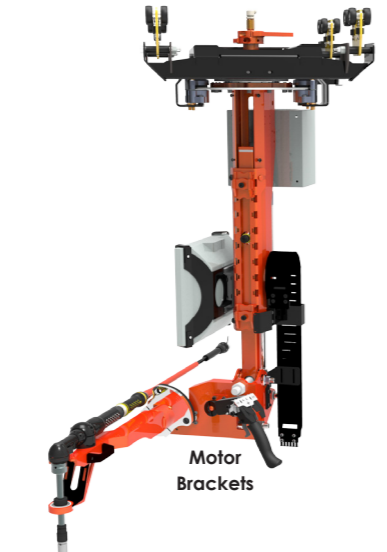

Motor Brackets

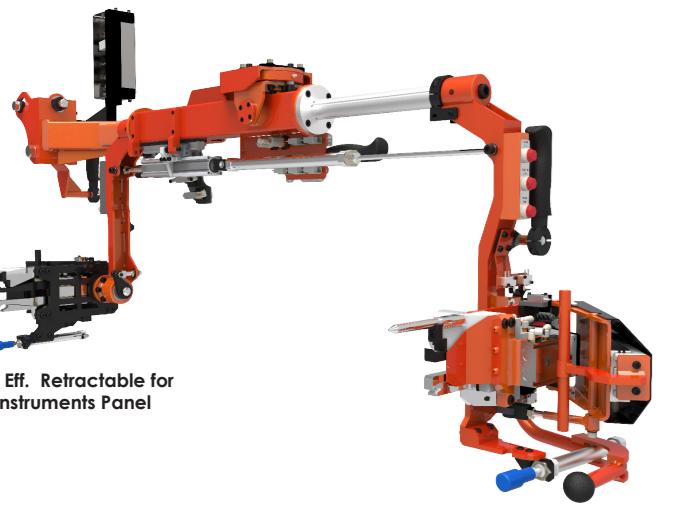

End Eff. Retractable for Instruments Panel



Seat Transfer

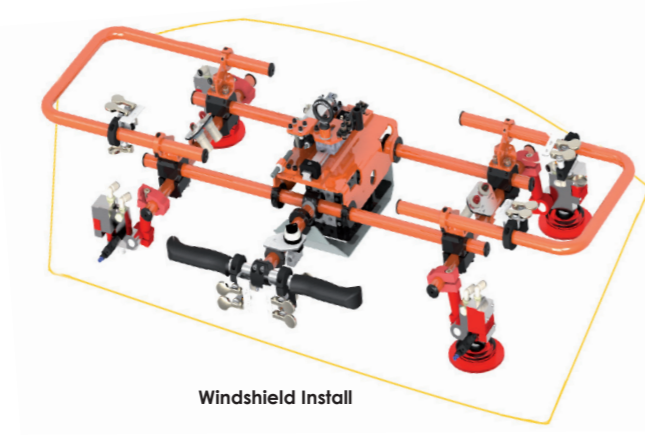

Windshield Install



Panels Transfer

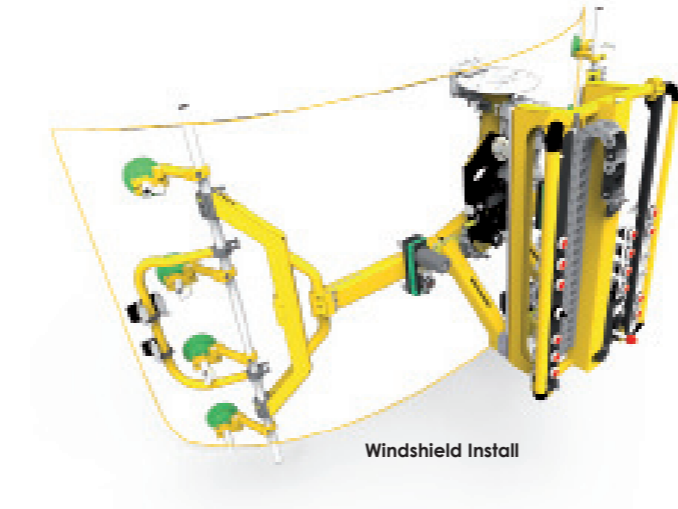

Windshield Install



Windshield Install



Instrument Panel Install

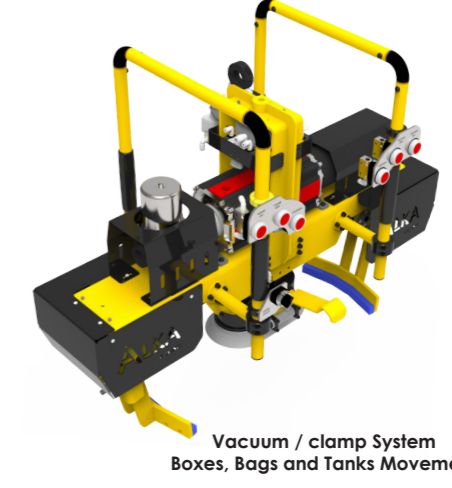

Vacuum / clamp System Boxes, Bags and Tanks Movement



Back Door Install

- Design based on **ANSI, OSHA, CASME, NERMA, NTP Standards.**
- All of the system components have been tested .

Applications

- Suspended Runways and Cranes.
- For hoists.
- Pneumatic and electric track Cranes for handling loads.

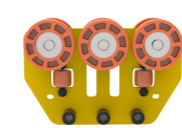
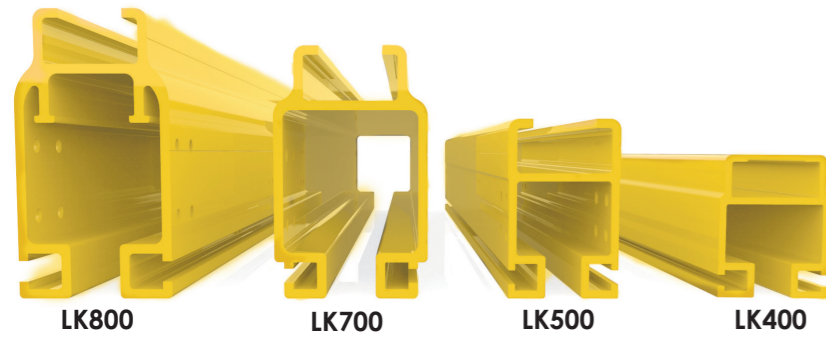

Trolley Telescope
1650 Lbs / 750Kgs

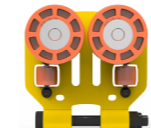

Universal Trolley
1100 Lbs / 500 Kgs

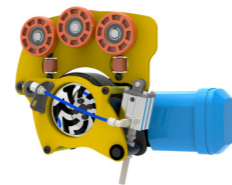

Electric Car Track



Pneumatic Car Track

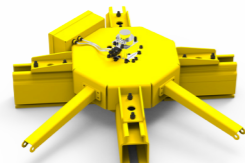

Turntable



Curve: 10°, 15°, 45°, 60°, 90°.

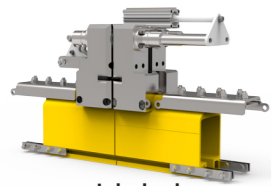

Interlock

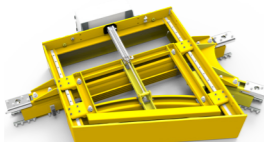

Track Switch



Control Keypads

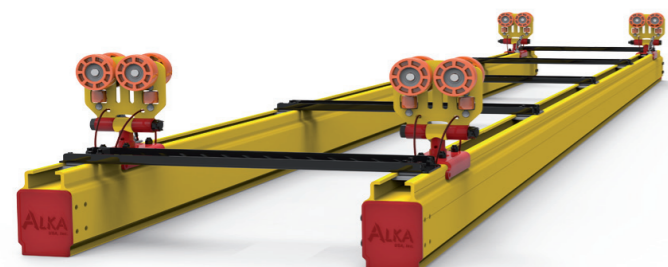

Aluminium Twin Bridge Crane

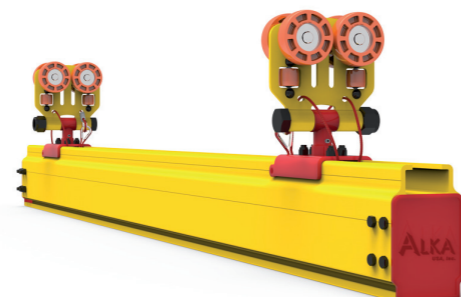

Aluminium Single Bridge Crane

- Cranes for 260° and 360° arm rotation
- Ideal for short load transfers
- The Jib Cranes work with aluminum or steel rails
- Easy to handle and ergonomic

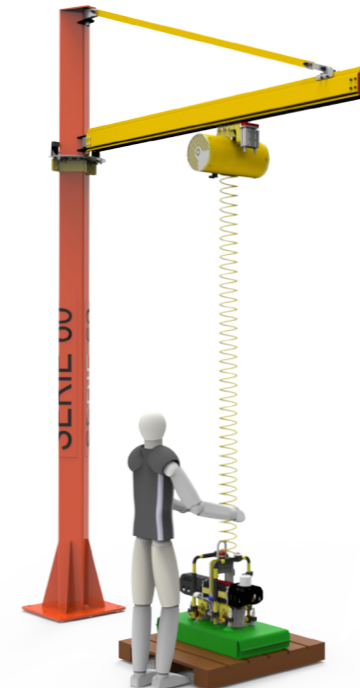

Motorized Jib Crane 360°

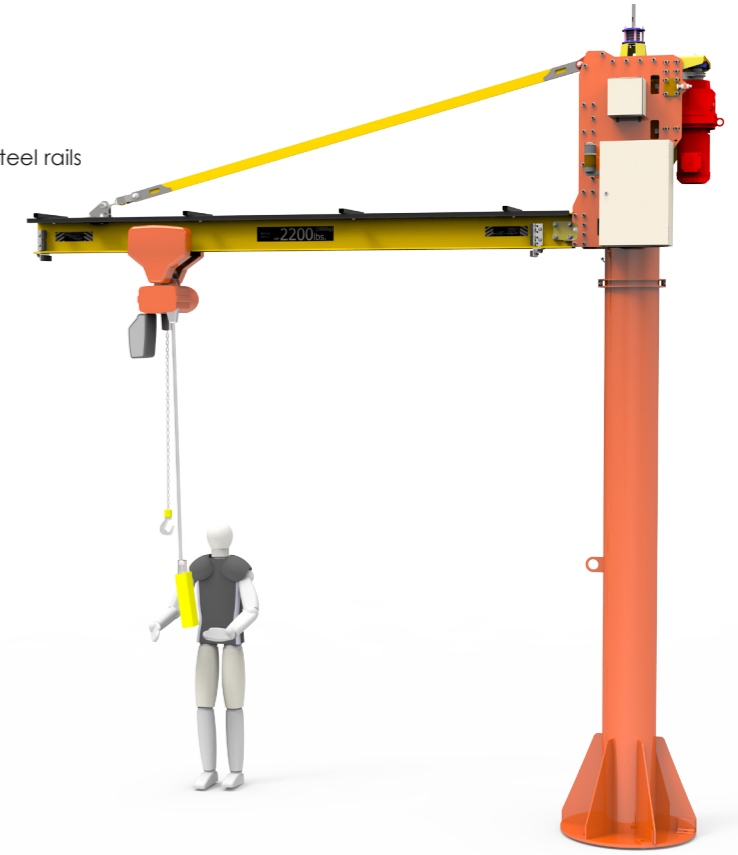

Motorized Jib Crane 360°



Jib Crane 260°



Jib Crane 260°



Jib Crane 260°

Date:

ALKA
USA Inc.



► NOTES:

► **ALKA USA Inc.**
MEXICO
Balneario 8, Texcacoa, Tepetzotlán
Tel 01 (55) 50254371 / 72
Edo. Mex. CP 54605
ventas@alkausainc.com

► **ALKA USA Inc.**
USA
2408 Royal Lytham Dr. Austin TX 78747
Ph. (512) 292 4000 Fax (512) 431 88 08
sales@alkausainc.com

ALKA USA Inc CAT-0613/17.1
© Copyright